

SF-M10: dc metal brushed motor

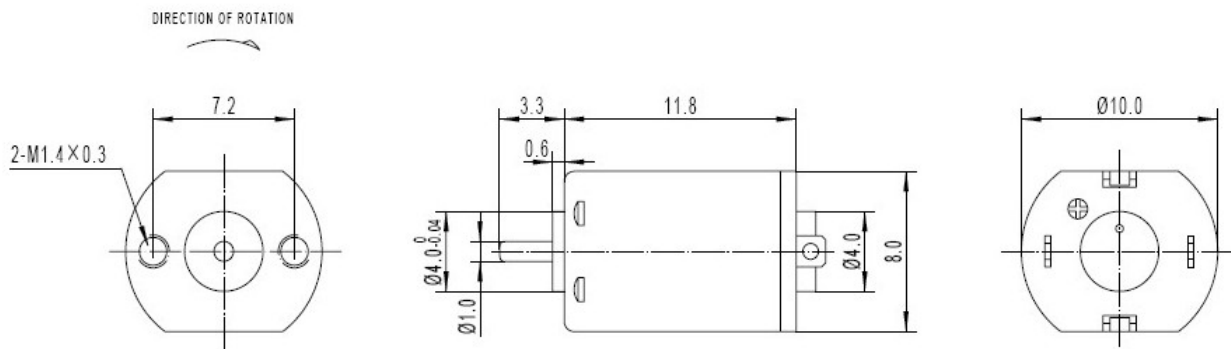

Description

- 1.Size: 10*8.1*11.8 mm
- 2.Voltage: 4.5 V
- 3.Speed: 21500 rpm
- 4.Rated torque: 1.6 g.cm
- 5.Specs can be customized for you



Voltage V	No load		At load				Stall	
	Speed/rpm	Current/A	Speed/rpm	Current/A	Torque/g.cm	Power/W	Current/A	Torque/g.cm
4.5	21500	0.032	17260	0.13	1.6	0.28	0.53	8.2
4.5	19600	0.03	15300	0.11	1.4	0.21	0.38	6.2

TEL:+86-755-89480927
 FAX:+86-755-88366423
 Web: www.sonth123.com
 Msn: sonth123@hotmail.com