

SBL57: dc brushless motor

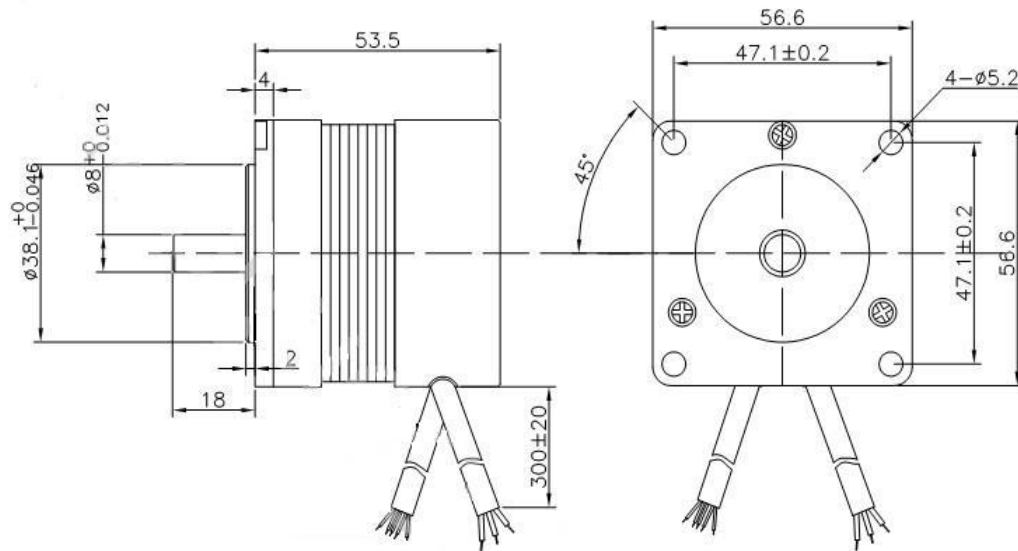

Description

- 1.Size: 56.6*53.5 mm
- 2.Voltage: 24V
- 3.Speed: 6500 rpm
- 4.Rated torque: 600 g.cm
- 5.Ball bearing



Voltage V	No load		At load				Stall	
	Speed/rpm	Current/A	Speed/rpm	Current/A	Torque/g.cm	Power/W	Current/A	Torque/g.cm
24	7000	0.8	6500	2.4	600	50	7.5	2000

TEL:+86-755-89480927
 FAX:+86-755-88366423
 Web: www.sonth123.com
 Msn: sonth123@hotmail.com